

Linha C - Freio 2C / 1C

C Line - 2C / 1C Brake

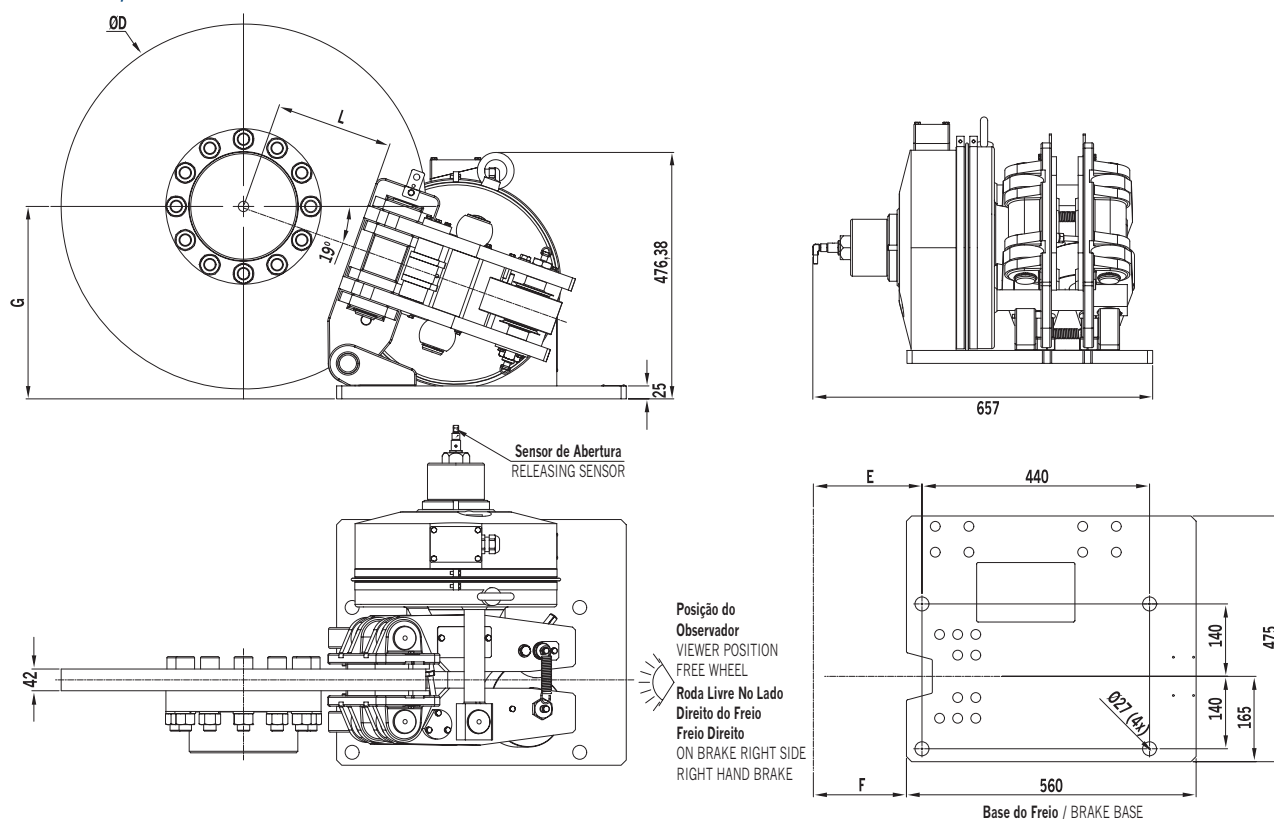

Peso / Weight:	250 [kgf]	Regulagem de desgaste / Worn-out adjusting:	Automática / self-adjusting
Frenagem / Applying:	Por Molas / Spring	Espessura do disco (e) / Disc thickness (e):	42 [mm]
Desfrenagem / Releasing:	Electromagnética / Electromagnetic	Tempo de Resposta / Response time:	0,2 [s]
Faixa de Regulagem do Torque: / Torque adjustment range:	20% a-30%		

Discos / Discs	Dimensões [mm] / Dimensions [mm]				Torque de Frenagem [Nm] / Braking Torque [Nm]	Força de Frenagem [N] / Braking Force [N]
ØD [mm]	E	F	G	L	TF	EF
550	134	104	345	145	3.325	15.100
625	157	127	353	180	3.890	15.100
705	210	180	372	225	4.495	15.100
795	250	220	385	265	5.175	15.100
995	345	315	415	370	6.685	15.100

Freio 1C - Peso: 320 [kgf] / 1C Brake - Weight: 320 [kgf]

Discos / Discs	MF	EF	Dimensões Principais [mm] / Main Dimensions [mm]															
ØD [mm]	[Nm]	[N]	A	B	C	D	E	F	G	H	I	J	K	L	M	N	P	α
550	4.680	21.290	475	560	140	440	134	104	345	467	25	Ø27	165	145	100	592	42	19° 33
625	5.480						157	127	353					180				
705	6.630						210	180	372					225				
795	7.290						235	220	385					265				
995	9.420						345	315	415					370				